

CP300 Composite Level Railing With Aluminum Balusters

FAIRWAY RAILING™

BY **Envision**
OUTDOOR LIVING PRODUCTS

It is the responsibility of the installer to meet or exceed all code and safety requirements, and to obtain all required building permits. These instructions are only a guide and may not address every circumstance. The deck and railing installer should determine and implement appropriate installation techniques for each situation.

FAIRWAY Architectural Railing Solutions, shall not be held liable for improper or unsafe installations.

1 Measure Rail Length

Plumb post/mounting surface. Slide base trim ring and sleeve over post. Measure distance between mounting surfaces.

NOTE: For 5 1/4" x 5 1/4" Post Sleeves - Top Bracket Only For added strength you may add a 3/4" x 2 1/4" x 6" composite or treated wood block (block not supplied) between post sleeve & wood post before installing top bracket.

Labels: Top Rail Bracket, 3/4" X 2-1/4" X 6" Composite or Wood Block, 5-1/4" X 5-1/4" Fx2 Post Sleeve, 4" X 4" Structural Post.

2 Install Bottom Rail Mounting Screw

Labels: Post Sleeve, Bottom Rail, Bottom Mounting Bracket, Post Sleeve, Check Clearance With Bottom Bracket, #14 x 2" Mounting Screw, 2" Space, 3/8" to Center of Hole, Pre Drill 3/16" Hole.

Install Bottom Rail Mounting Screw
Find center of post/mounting surface (Example: 5-1/4" post = 2-5/8"). Mark center line on surface. Determine distance from finish deck to bottom of rail. Add 3/8" and mark. Drill 3/16" hole on center of center line. Install #14 x 2" screw to within 1/8" of mounting surface. Check screw head clearance using a bottom bracket and adjust clearance between screw head and post/mounting surface to obtain a snap in fit.

NOTE: Using Fairway's Structural Post with 4" x 4" CP300 Post Sleeve, requires using "SK1 - 4" post sleeve" screw packs provided with all mounting bracket kits. Shorter mounting screws will not interfere with steel support post (may also use with wood post).

3 Cut Rails to Length

Labels: BOTTOM RAIL, Measurement From Step #1, Equal & Maximum End Spacing, SUB-RAIL, Measurement From Step #1, Deduct 1/8" for Top Rail Bracket.

Cut Rails to Length
Using measurement from step #1, cut bottom rail to length. Make certain there is equal and maximum distance on end spacing. If posts are plumb, measure sub-rail same length, DEDUCT 1/8" from each end and cut to length.

4 Install Railing and Foot Block Mounting Brackets

Labels: (A) BOTTOM RAIL, Bottom Rail, Keep Mounting Bracket Flush w/End of Rail, (B) SUB-RAIL, Sub-Rail, Pre-Drill Two 1/8" Holes for #10 Screws, #10 X 1-3/4" Will be Installed With Top Rail In Step #7, 1/8" Beyond End of Rail, (C) FOOT BLOCK, #10 x 3/4" Screw, Bottom Rail, Center of Bottom Rail.

Install Railing and Foot Block Mounting Brackets
(A) Place bottom rail bracket on underside of bottom rail with **post mounting flange pointing up**. Make certain post flange is flush with the end of the bottom rail and mark the elongated slot. Drill a 1/8" hole in the center of elongated slot on each bracket and install one each #10 x 3/4" mounting screw for each bracket. Adjust bracket if necessary.
(B) With Baluster Connectors facing up, slide Top Rail Brackets with mounting flanges pointing down on end of Top Sub-Rail. On elongated slot closest to mounting flange, find center & drill a 1/8" pilot hole. On other slot, drill a 1/8" pilot hole on outer edge of slot closest to baluster connector (see illustration). Install One #10 x 3/4" center hole on elongated slot (second screw will be installed in STEP# 7).
(C) Find center of rail & install foot block mounting bracket with one #10 x 3/4" screw.

NOTE: TWO FOOT BLOCKS ARE REQUIRED FOR 10' KITS - Divide finish bottom rail length into 1/3 (thirds). Install two (2) foot block brackets. Center brackets on bottom rail and screw in place with #10 x 3/4" SS white head screw.

5 Assemble Rail Section

Place cut rails on a non-abrasive surface. (A) Screw aluminum baluster connectors to rails in pre-drilled locations using provided hardware. (B) Lay bottom rail with baluster connectors facing up and set balusters in place using a rubber mallet. (C) With balusters installed in bottom rail, set sub-rail in place and starting at one end, tap Sub-rail onto top of balusters. (D) Using measurement from Step #2 (Distance from finish deck to bottom rail) add 7/8". Cut foot block (supplied) and clip onto foot block bracket.

Labels: (A), (B), (C), (D) FOOT BLOCK.

6 Install Rail Section

Labels: Seat Bottom Bracket on #14 x 2" Screw, Install Two #10 x 2-1/4" Screws, Center Line of Mounting Surface, Pre-Drill Two 1/8" Holes, (See NOTE, Step 2).

Install Rail Section
Place rail section between posts/mounting surfaces above bottom screw. Slide rail section down to engage bottom mounting bracket onto screw. Find center of post/mounting surface and center top mounting bracket. Pre-drill two 1/8" holes through top mounting bracket holes into post/mounting surface and install two each "non-painted" #10 x 2-1/4" screws in both ends of rail. (See NOTE, Step 2)

7 Install Top Rail

Labels: 1-3/4" Screw Through Open Slot in Bracket, 1-3/4", 1-3/4", 1-3/4" Screw Through Open Slot in Bracket.

Install Top Rail
With rail section mounted in place, measure inside distance between post/mounting surface. Cut TOP RAIL to length. Slide TOP RAIL over sub-rail. In the inner second slots of top rail brackets install a #10 X 1-3/4" screw in pre drilled hole. Find "quarter points" between post, pre-drill and install the two additional #10 x 1-3/4" screws.

CP300 Composite Stair Railing With Aluminum Balusters

FAIRWAY RAILING™



It is the responsibility of the installer to meet or exceed all code and safety requirements, and to obtain all required building permits. These instructions are only a guide and may not address every circumstance. The deck and railing installer should determine and implement appropriate installation techniques for each situation.

FAIRWAY Architectural Railing Solutions, shall not be held liable for improper or unsafe installations.

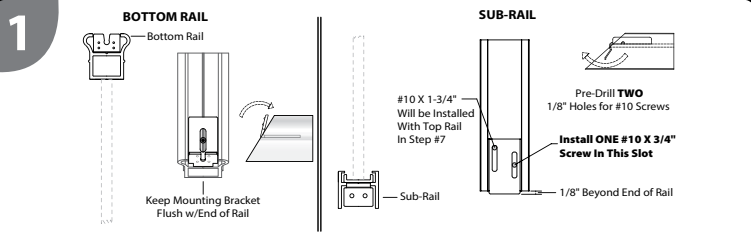

Measure Rail Length

Plumb post/mounting surface. Slide base trim ring and sleeve over post. Measure distance between mounting surfaces.

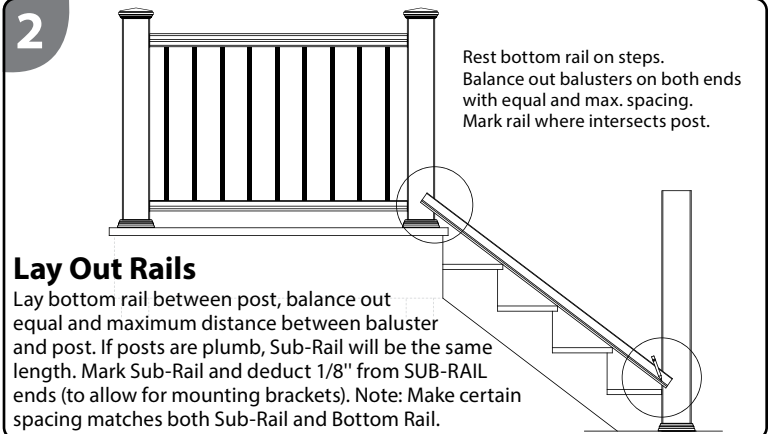

Lay Out Rails

Lay bottom rail between post, balance out equal and maximum distance between baluster and post. If posts are plumb, Sub-Rail will be the same length. Mark Sub-Rail and deduct 1/8" from SUB-RAIL ends (to allow for mounting brackets). Note: Make certain spacing matches both Sub-Rail and Bottom Rail.

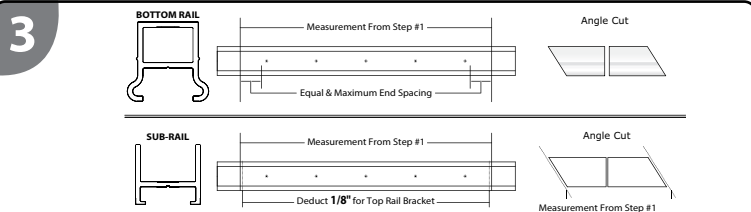

Cut Rails to Length

With angle and stair rail run marked and cut to length. Make certain on **SUB-RAIL ONLY to deduct 1/8"** from each end to allow for mounting bracket. NOTE: Make certain there is equal and max. distance between baluster and post on both rail ends. Also check to see if top and bottom rails match to provide plumb baluster installation.

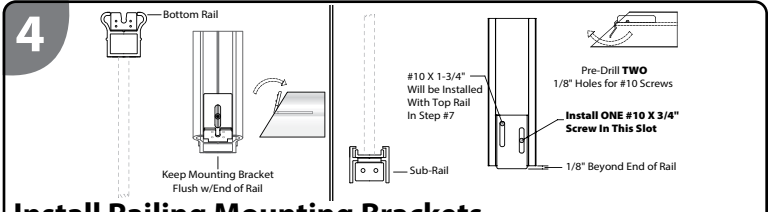

Install Railing Mounting Brackets

Bottom Rail Brackets: Place bottom rail bracket on bottom of rail with **post mounting flange pointing up**. Make certain post flange is flush with the end of the bottom rail and mark the elongated slot. Drill a 1/8" hole in the center of elongated slot and install a #10 x 3/4" mounting screw. **Top Rail Brackets:** Top Rail Brackets with mounting flange pointing down on end of Top Sub-Rail. On elongated slot closest to mounting flange, find center & drill a 1/8" pilot hole. On other slot, drill a 1/8" pilot hole on outer edge of slot closest to baluster connector (see illustration). Install ONE #10 x 3/4" center hole on elongated slot (second screw will be installed in STEP# 8). Adjust bracket angles if necessary.

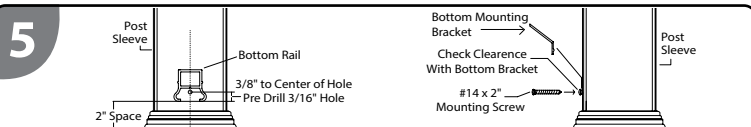

Install Bottom Rail Mounting Screw and Foot Block

Mark center line of post/mounting surface (Example: 5-1/4" post = 2-5/8"). Determine distance from bottom rail to stair nosing (See local building codes for height limitations), center bottom rail with center line of post and mark slot in mounting bracket. Drill a 3/16" hole and Install #14 x 2" screw to within 1/8" of post. Set bottom rail in place, locate the center (as close as possible) stair tread and measure the distance from tread to bottom of rail. Cut foot block to length (one end cut to match stair pitch), slide foot block in place (make certain bottom rail is resting on mounting screws) and mark front and back of foot block onto bottom rail. Remove bottom rail, turn with bottom side exposed and locate foot block marks. Install foot block keeper (supplied) between marks. Slide Foot Block over keeper and set rail in place. Adjust if necessary and remove. Remember to install foot block after rail is assembled and ready to set in place.

NOTE: Using Fairway's Structural Post with 4" x 4" Fx2 Post Sleeve, requires using "SK1 - 4" Post Sleeve" screw packs provided with all mounting bracket kits. Shorter mounting screws will not interfere with steel support post (May also use with wood post).

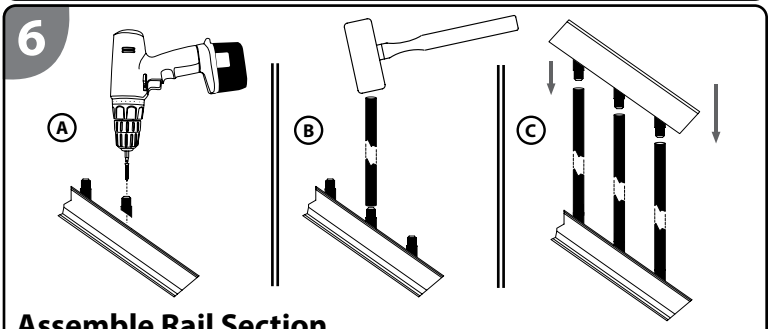

Assemble Rail Section

Place cut rails on a non-abrasive surface. (A) Screw aluminum baluster connectors to rails in pre-drilled locations using provided hardware. (B) Seat aluminum balusters on bottom rail baluster connectors with a rubber mallet. (C) With balusters installed in bottom rail, set sub-rail in place and starting at one end, tap sub-rail into top of balusters.

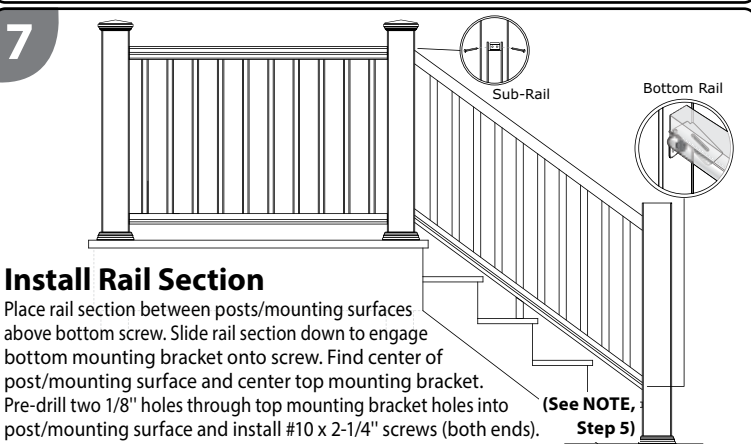

Install Rail Section

Place rail section between posts/mounting surfaces above bottom screw. Slide rail section down to engage bottom mounting bracket onto screw. Find center of post/mounting surface and center top mounting bracket. Pre-drill two 1/8" holes through top mounting bracket holes into post/mounting surface and install #10 x 2-1/4" screws (both ends). (See NOTE, Step 5)

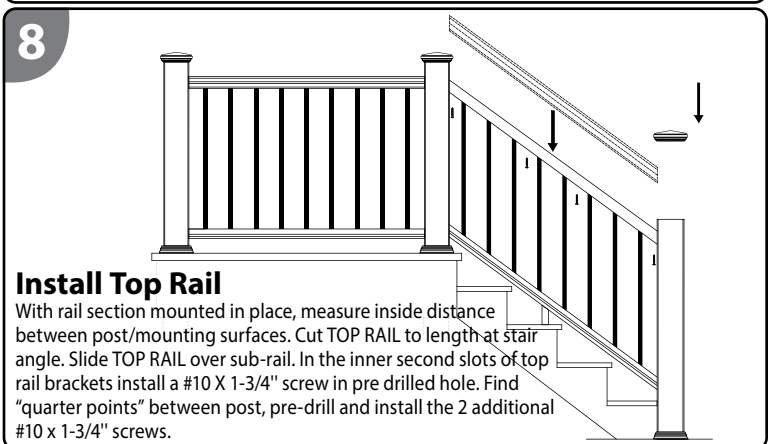

Install Top Rail

With rail section mounted in place, measure inside distance between post/mounting surfaces. Cut TOP RAIL to length at stair angle. Slide TOP RAIL over sub-rail. In the inner second slots of top rail brackets install a #10 X 1-3/4" screw in pre drilled hole. Find "quarter points" between post, pre-drill and install the 2 additional #10 x 1-3/4" screws.